

PT580 Digital Vibration Switch

Introduction

The PT580 Digital Vibration Switch is designed to be the “one stop shop” for all vibration switch applications. The PT580 is fully programmable, suitable for harsh environments and hazardous areas. It has a universal mounting feature, wide operating temperature range, dual alarms, 4-20mA output, Modbus communication, and works with an internal or a remote sensor.

Applications

- ✓ Pumps
- ✓ Motors
- ✓ Industrial Fans
- ✓ Heat Exchangers/ Cooling Towers
- ✓ Engines
- ✓ Reciprocating Compressors
- ✓ Centrifuges
- ✓ Rock or Coal Crushers

Features

- ✓ The first digital vibration switch
- ✓ Direct replacement for mechanical switches with universal mounting plates and studs
- ✓ Fully programmable
- ✓ 4-20mA output and Modbus
- ✓ Dual alarms with relays or triacs
- ✓ Works with internal or external sensor
- ✓ “Smart Design” universal power supply
- ✓ Wide operating temperature range of -52°C to +75°C (-62°F to +167°F)
- ✓ NEMA 4X(optional E-coating), IP65 environmental rating
- ✓ Hazardous area approvals: CSA, CE, ATEX, PCEC,TR CU
- ✓ Additional API 670 features: trip-multiply, bypass, programmable alarm delay etc.

Specifications

Frequency Range:

Internal sensor: 2 - 1,000 Hz
External sensor: 2 - 2,000 Hz



Alarms: Dual alarms

Dry-contact relay: 5A 230VAC/115VAC or 5A 30VDC
Triac: 5A 230VAC. Optically Isolated, Standard NC

Temperature Limit:

-52°C to +75°C (-62°F to +167 °F)

Power Supply:

95 - 250VAC@ 100mA, 50 - 60Hz, or
22 - 30VDC @ 200mA

Enclosure: Cast Aluminum

Coating: Standard plastic coating on outside of surface, or E-coating for optional on both inside and outside of surfaces and mounting plate (AL alloy). Mounting stud and local reset are SS304.

Environmental Rating:

NEMA 4X(optional E-coating), IP65

Programming (Customer Selects The Option):

Fully programmable with software or
Pre-configured at factory

Hazard Rating: See order information

IECEX: Ex db IIC T4/T6 Gb
Ex db IIB+H₂ T4/T6 Gb
IECEX DEK 16.0002X

IEC 60079-0: 2011

IEC 60079-1: 2014

ATEX: II 2G Ex db IIC T4/T6 Gb

II 2G Ex db IIB+H₂ T4/T6 Gb

T4@Ta= -52°C to +100°C

T6@Ta= -52°C to +70°C

DEKRA 16ATEX0003X

EN 60079-0: 2012



EN 60079-1: 2014

TR CU : 1Ex db IIC T4, T6 X Gb

1Ex db IIB+H2 T4, T6 X Gb

№ TC RU C-US.AA87.B.01024

NANIO CCVE

GOST 31610.0-2014 (IEC 60079-0: 2011) Explosive atmospheres. Part 0. Equipment. General requirements and GOST IEC 60079-1-2013 Explosive media. Part 1. Equipment with type of protection "flameproof enclosure" d ".

Physical

Temperature:

Operation: -52°C to +75 °C (-62 °F to +167 °F)

Storage: -52°C to +120°C (-62°F to +248°F)

Dimensions:

See attached drawing

Weight:

1.4kg (3 lbs)



Order Information

PT580-ABC-DEF-GGHI

A: Alarms***

- A = 0*: Dual SPDT Relays
- A = 1: Single SPDT Relay
- A = 2: Single SPST Triac, NO
- A = 3: Dual SPST Triacs, NO
- A = 4: Single SPST Triac, NC
- A = 5: Dual SPST Triacs, NC
- A = 6: None

B: Conduit Entries

- B = 0*: 3/4" NPT
- B = 1: M20x1.5

C: Mounting Plate or Mounting Stud

- C = 0*: Mounting Plate PT500-13
- C = 1: Mounting Plate PT500-14
- C = 2: Mounting Stud 3/4" NPT
- C = 3: Mounting Stud M20x1.5

D: Local Display

- D = 0*: With display (No Local Reset)
- D = 1: No display (No Local Reset)
- D = 2: No display (With Local Reset)

E: Hazardous Area Approval

- E = 0*: CE Mark
- E = 1: Multiple approvals:
 - CSA: Class I, Div 1, Groups B, C, D, T4 & T6
CERTIFICATE: 2079756
 - ATEX: II 2G Ex db II B+ H₂ T4/T6 Gb
T4@Ta= -52°C to +100°C
T6@Ta= -52°C to +70°C
DEKRA 16ATEX0003X
 - IECEX: Ex db II B+ H₂ T4/T6 Gb
IECEX DEK 16.0002X
 - PCEC: Ex d II B+H₂T4/T6 Gb
CE Mark
- E = 2: Multiple approvals (D=1 only) :
 - CSA: Class I, Div 1, Groups A, B, C, D, T4 & T6
CERTIFICATE: 2079756
 - ATEX: II 2G Ex db II C T4/T6 Gb
T4@Ta= -52°C to +100°C
T6@Ta= -52°C to +70°C
DEKRA 16ATEX0003X
 - IECEX: Ex db II C T4/T6 Gb
IECEX DEK 16.0002X
 - PCEC: Ex d IIC T4/T6 Gb
CE Mark

E=3: Multiple approvals:

- TR CU: 1Ex db IIB+H₂ T4, T6 X Gb
- № TC RU C-US.AA87.B.01024
- NANIO CCVE
- CE Mark

E=4: Multiple approvals(D=1 only):

- TR CU: 1Ex db IIC T4, T6 X Gb
- № TC RU C-US.AA87.B.01024
- NANIO CCVE
- CE Mark

F: Outputs/Communication

- F = 0: None
- F = 1*: 4-20mA
- F = 2: Modbus
- F = 3: 4-20mA and Modbus

GG: Full Scale

- GG = 09: 0 - 5.0g pk
- GG = 10: 0 - 10.0g pk
- GG = 11: 0 - 20.0g pk
- GG = 13: 0 - 200 um pk-pk (with H=2)
- GG = 14: 0 - 250 um pk-pk (with H=2)
- GG = 15: 0 - 500 um pk-pk (with H=2)
- GG = 16: 0 - 10 mil pk-pk (with H=2)
- GG = 17: 0 - 20 mil pk-pk (with H=2)
- GG = 20: 0 - 12.5 mm/s pk
- GG = 21: 0 - 20mm/s pk
- GG = 22: 0 - 25mm/s pk
- GG = 23: 0 - 50mm/s pk
- GG = 24: 0 - 100mm/s pk
- GG = 30: 0 - 12.5 mm/s rms
- GG = 31: 0 - 20mm/s rms
- GG = 32*: 0 - 25mm/s rms
- GG = 33: 0 - 50mm/s rms
- GG = 34: 0 - 100mm/s rms
- GG = 40: 0 - 0.5ips pk
- GG = 41: 0 - 1.0ips pk
- GG = 42: 0 - 2.0ips pk
- GG = 43: 0 - 4.0ips pk
- GG = 50: 0 - 0.5ips rms
- GG = 51: 0 - 1.0ips rms
- GG = 52: 0 - 2.0ips rms
- GG = 53: 0 - 4.0ips rms

H: Sensors

- H = 0*: Internal accelerometer
- H = 1: TM0782A or accelerometer with 100mV/g
(purchase separately)
- H = 2: TM0793V or velocity sensors with 4.0 mV/mm/s
(purchase separately)

I: Power Supply



I = 0*: 115VAC or 230VAC

I = 1: 24VDC

Note:

* Factory default

*** Alarm delays 6s and relay works in non-energized mode.

Optional Accessories

PT580-CFG-K

Configuration and calibration software kit includes:

- ✓ PT580-CFG configuration software CD
- ✓ RS485-USB converter with cable
- ✓ User manual

PT580-CFG

Configuration and calibration software only includes:

- ✓ PT580-CFG configuration software CD
- ✓ User manual

RS485-USB

Cable with RS485 to USB connections for configuration with laptop computer

DTM-96

The system interface module converts the modbus output from the PT580 to an isolated RS232, RS422 or RS485 protocol for communication with PLC or DCS. Each DTM-96 can connect up to 32 PT580 switches.

PCM370

The PCM370 condition monitoring software is ideal for plant wide condition monitoring. The PCM370 requires the DTM96 to communicate with the PT580.

PCM-TOUCH

Touch panel PC with IP65 rating. Ideal to work with PCM370 and PT580-CFG.

Mechanical Outline Drawing

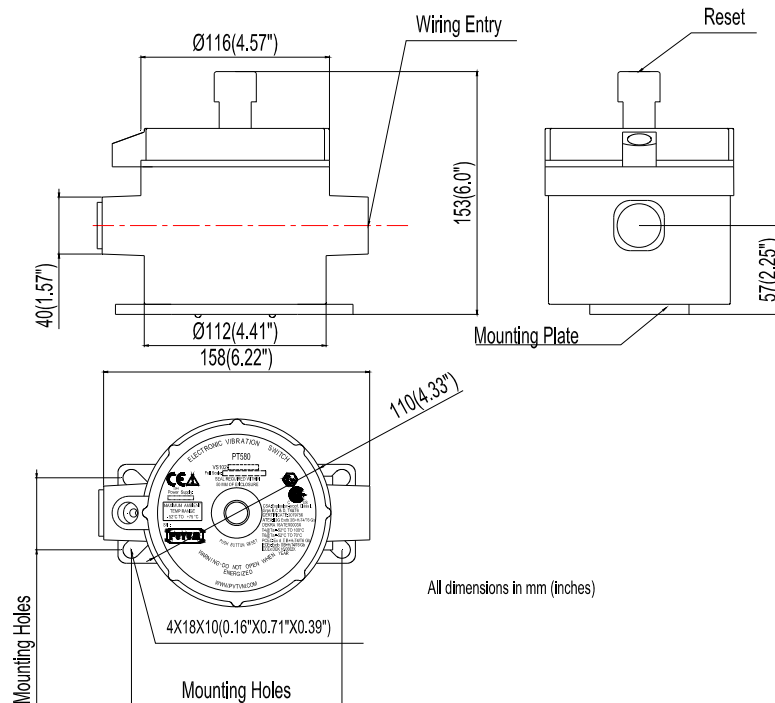
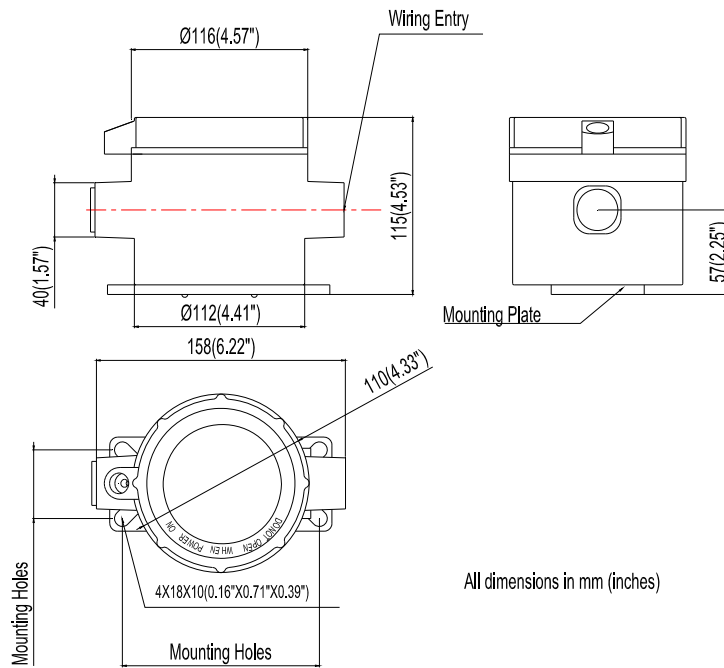

Mounting Plate, Mounting Studs

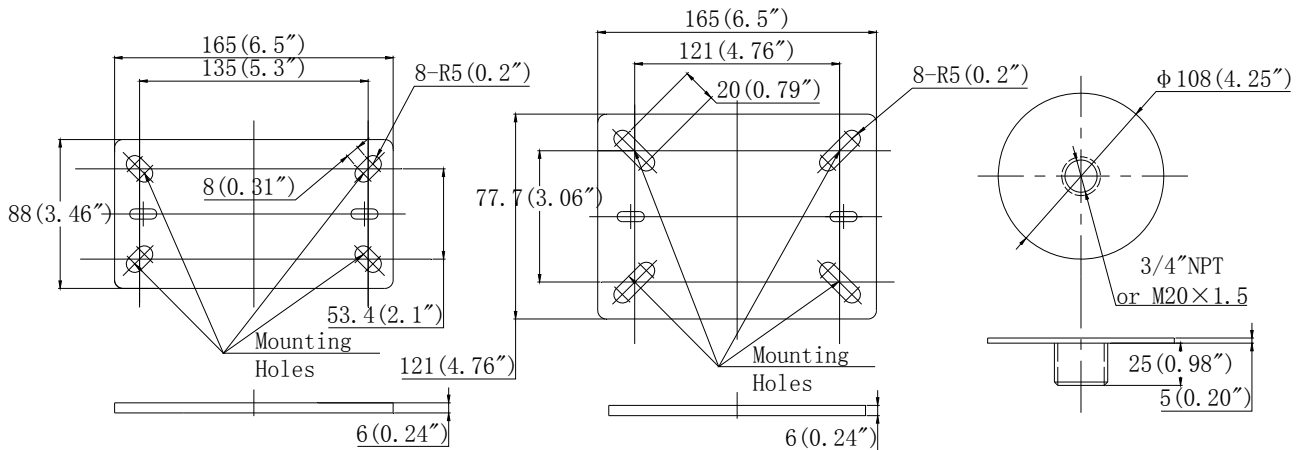

All dimensions in mm (inches)

PT500-13

PT500-14

PT500-15 (3/4" NPT)

PT500-17 (M20x1.5)

Plate is consistent with the direction of Conduit Entries, as shown below. If customers need other installation direction, please be sure to mark it clearly in purchase order.

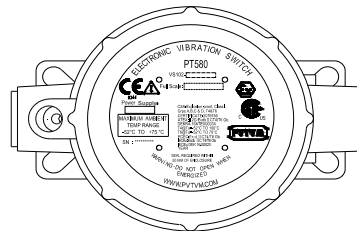

Accessories



Cover1* (D=2) PT500-2	Cover2* (D=1) PT500-3	Cover3* (D=0) PT500-1	magnetic ring** PT500-10
-----------------------------	-----------------------------	-----------------------------	-----------------------------

Field-Wiring Diagram

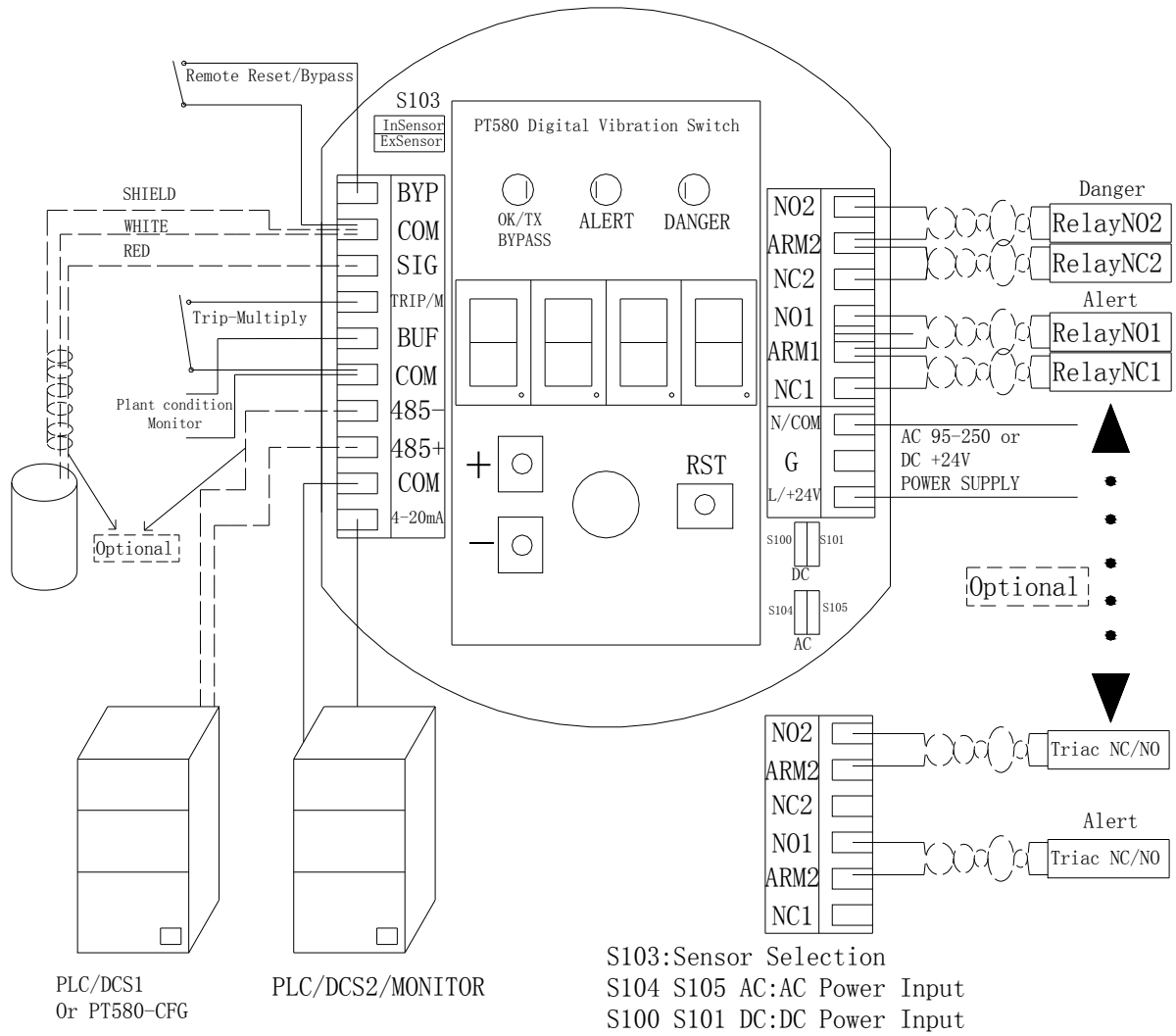

Communication Diagram

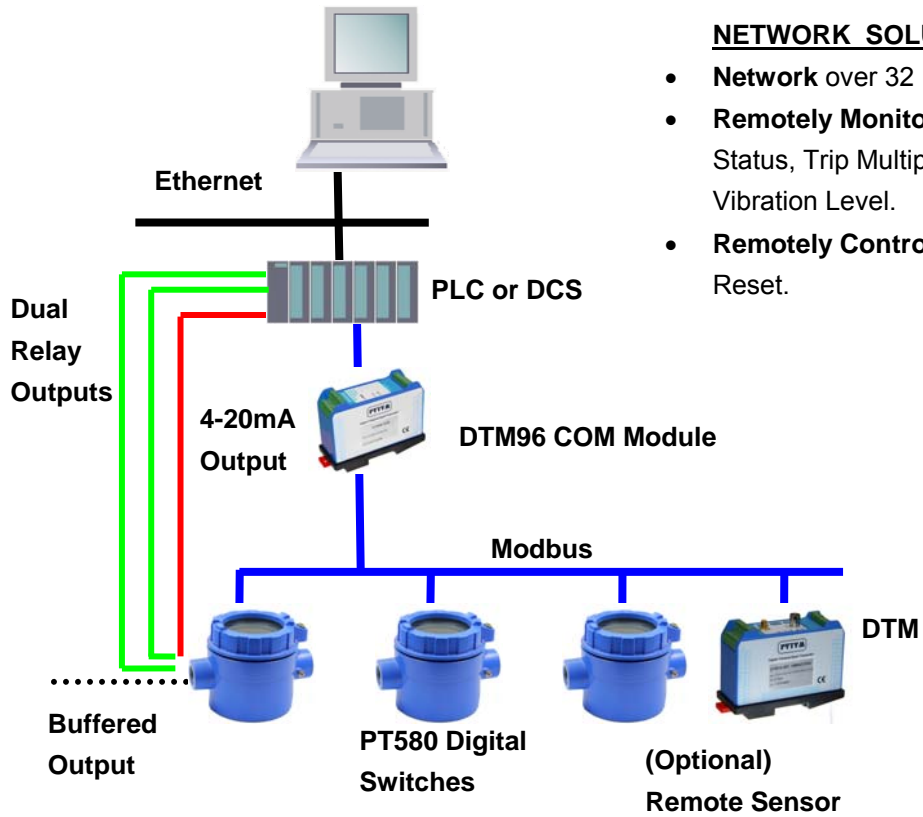

NETWORK SOLUTIONS

- **Network** over 32 PVTVM devices together.
- **Remotely Monitor:** Alarm and Channel OK Status, Trip Multiply, Bypass and Overall Vibration Level.
- **Remotely Control:** Trip Multiply, Bypass and Reset.

Traditional Solution

- 4-20mA
- Relay Outputs
- Modbus

